

# 三相誘導電動機 THREE-PHASE INDUCTION MOTOR

65/55  
32/28A

出力 OUTPUT (kW)	形 TYPE	式 FORM	定格 RATING	電圧 VOLTAGE (V)	周波数 FREQ. (Hz)	回転速度 SPEED (min <sup>-1</sup> )	極数 POLES	耐熱クラス TH. CLASS	質量 MASS (kg)
15	TFO	DR	S3 40%	200/220 400/440	50/60	960/1160	6	B	240

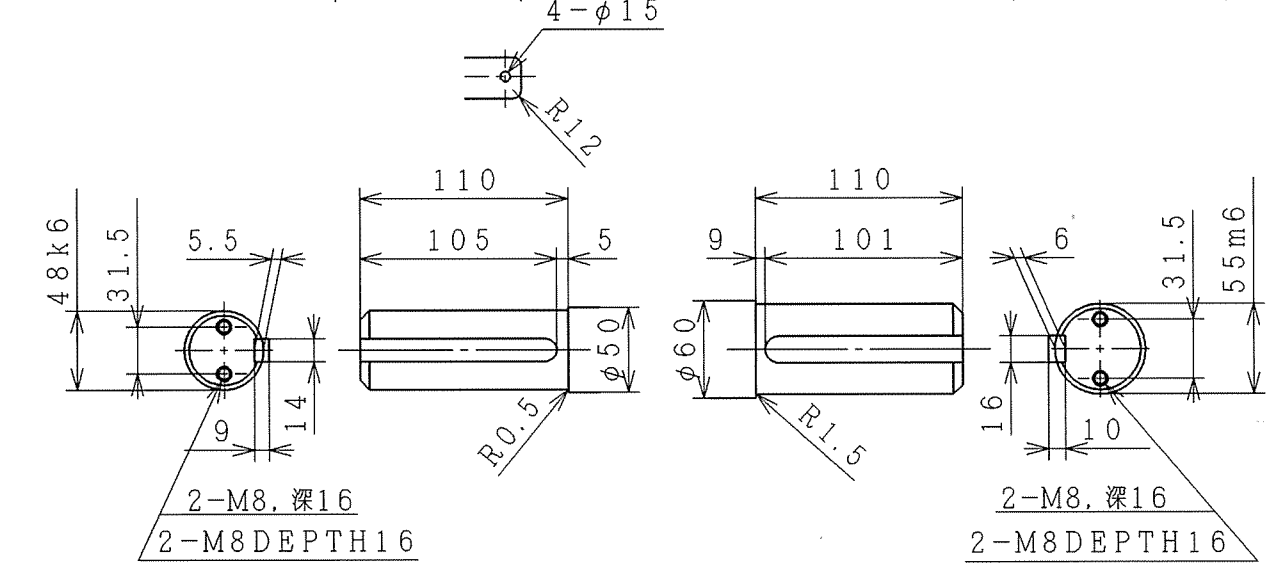
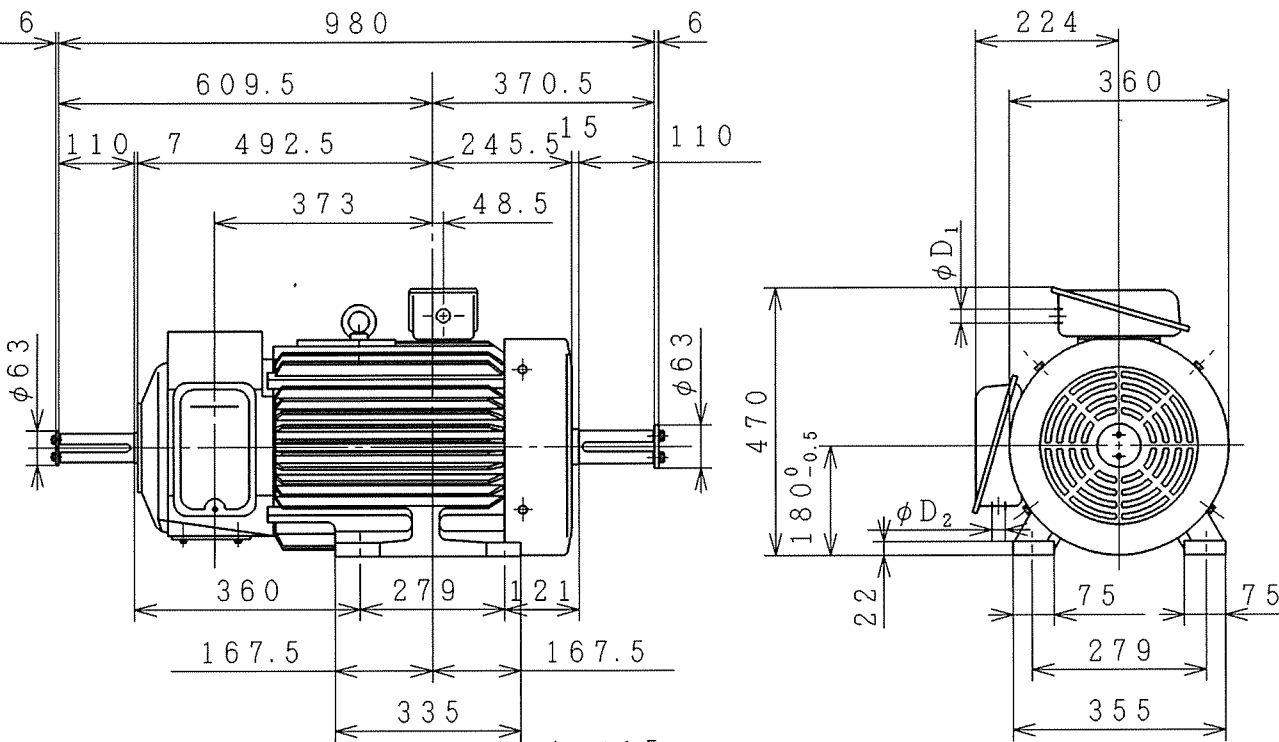

D <sub>1</sub>	D <sub>2</sub>

二次 200/220V, 47/142A



用途 USE \_\_\_\_\_

6313UU-6310UU

備考 NOTICE

御注文主 CUSTOMER

数量 QTY.

受注番号 ORDER No.

作業番号 WORK No.

REV.

殿

2

DWN. Y. JOHJIMA  
 CHKD. Y. JOHJIMA  
 APPD. K. KODAMA

寸法  
DIMENSIONS

Hitachi

NARASHINO WORKS DWG. No.  
3244R839841

SH.

種番 FRAME SIZE RTFOB-180L